

5000 System Specifications



KIP 5000 Printer

KIP 5000 systems are available in four main configurations to suit the needs of the most demanding printing and imaging environments:

- Monochrome Print System
- Monochrome Print & Copy System
- Monochrome Print, Copy and Scan System
- Mono/Color Print, Copy and Scan System

A space saving single footprint system, the KIP 5000 features an integrated touch screen operator panel designed for easy use. Menus are intuitive and user-friendly, ensuring simple operations for everything from walk-up job queue management to monochrome & color copying and scanning.

Features

- 8' D size prints per minute
- Copy, print and scan at true 600 x 600 dpi
- single, integrated footprint
- Advanced touch screen user interface provides all system functions
- One-touch mono & color copying to KIP 5000 and inkjet printer

Technology	LED printer with KIP HDP Plus Technology
Dot Size	.0017"
One Pixel Line	.0017"
DPI	600 x 600
Speed	8 'D' size prints per min, 3.9" per sec
Media	Automatic 2 roll with media bypass Automatic 4 roll with media bypass
Warm-up	Instant from standby 7 minutes from startup
Output	Minimum: 8.5" x 11" Maximum: 36" x 20' (standard)
Media Types	Bond 18-24 lb, Film 3.5 - 4 mil., Vellum/tracing 18-20 lb
Dimensions	53" (W) x 27" (D) x 35" (H)
Weight	510 lbs. (2 roll version) 595 lbs. (4 roll version)
Power	Standby 700 W
Consumption	Printing 1500 W
Electrical Requirements	120V +/-10%, 50/60Hz, 20A
Safety Approvals	Energy Star® qualified printer

KIP Image Processing System

Platform	KIP software with Windows XP
Network	TCP/IP, NetBEUI (smb), Novell
Protocols	(IPX/SPX), LPR/LPD
File Formats	DWF, PDF, HPGL 1/2, HP-RTL, Calcomp 906/907, CALS Group 4, TIFF Group 4, PCX, Intergraph CIT/TG4, Versatec Color Graphics (VCGL), Uncompressed Grayscale TIFF, TIFF Packbits, IBM IOCA, EDMICS (C4), TLC (KIP), PNG, JPEG

5000 System Installation



Space, Electrical, and Environmental Requirements

Compatible with all KIP 5002 & 5004 system configurations

Weight 510lbs (230kg) – 2 Roll
595lbs (270kg) – 4 Roll

Dimensions 53" (W) x 27" (D) x 35" (H)
(Operation panel not included) 136cm x 70cm x 90cm

Minimum Distance from Wall

rear dependent on stacker
left 39" (100 cm)
right 24" (61 cm)
front 39" (100 cm)

Total Space 116" (W) x 82" (D)
297 cm x 209 cm

Electrical (Dedicated) 20 amps, 120V

Electrical Receptacle Nema 5-20R

Power Consumption (watts)

running 1500W
standby 700W

Heat Emissions (BTU/hr.)

Running 4000BTU/hr.
Standby 2000BTU/hr.

Room Temperature 32-89°F (10-32°C)

Room Humidity 20-80%

Spatial Requirements

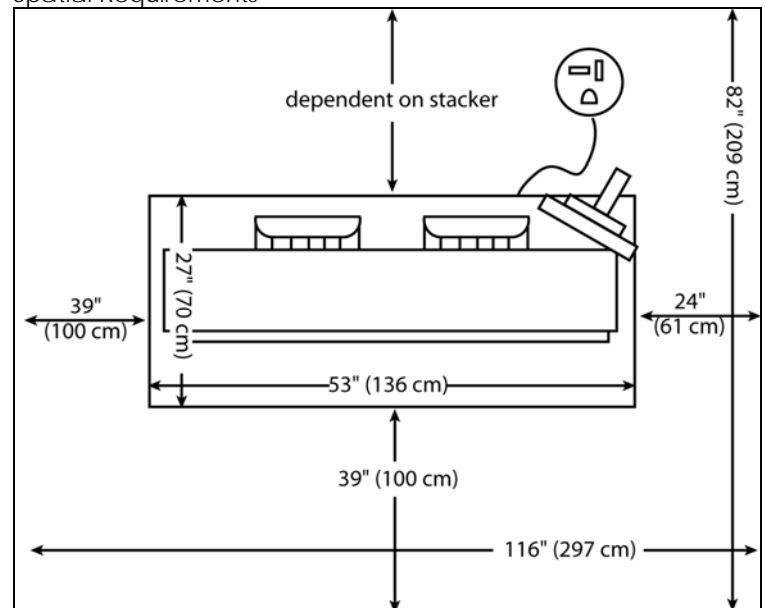

Top View, Not to Scale.